



sommer

MASCHINEN- & ANLAGENBAU



**MACHINE AND PLANT ENGINEERING
OF THE HIGHEST QUALITY**

Founded in 1895, SOMMER is today a major company for the manufacture and installation of machinery and plant that are used in a variety of production sectors. Our product range includes mixing systems and mixers, structural steel work, tank facilities and turnkey production systems.

We offer a comprehensive all-round service package that includes everything: initial customer discussions and subsequent design, production and delivery, installation and commissioning, as well as the handling of any peripheral organizational and approval requirements. This all leads to optimum order handling and processing, and to customized solutions for special requirements.

Experience, professionalism and success in many countries around the world. These are the main strengths that make SOMMER a reliable partner for the HAVER® GROUP.

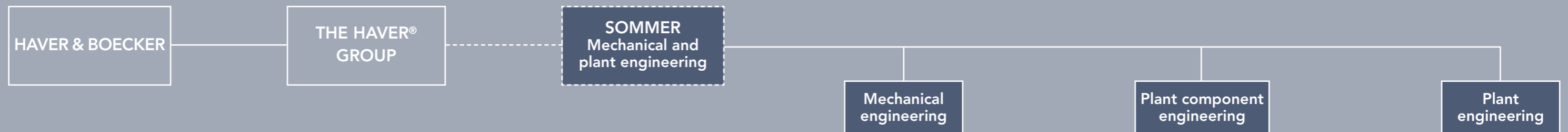

SOMMER is a high performance supplier of machinery and plant engineering

■ Mechanical engineering

Agitators, mixers, horizontal mixers, dissolvers, planetary mixers with outputs of up to 500 kW

■ Apparatus engineering

Mixing, storage and pressure vessels up to 4000 mm diameter and 50,000 liters capacity

■ Plant component engineering

Complete production systems, mixing and tank facilities with all the necessary piping, structural steelwork, fittings, pumps, valves and measurement and regulation systems, including fully automated facilities

■ Process control

Wiring of plant components, automation and visualization of processes, recipe and batch control systems as well as connection to existing ERP systems

With its years of experience in agitator and mixing technology, SOMMER is able to offer its customers process-optimized solutions.

Our range of services includes mixing trials using scale-ups, the layout of complete mixing and agitator processes, and the manufacture and installation of machines and systems.

Our premium-value machines and plant are mainly used in the paint, lacquer, plaster, and adhesive industries. But they can also be used in other sectors such as the chemicals, pharmaceuticals, oil and lubricant industries.



SOMMER has been a part of the **HAYER & BOECKER** Group since 2009. Ever since then, **SOMMER** and its sister company **FEIGE FILLING GmbH** have complemented each other as full system suppliers.

As leading global producers of plant, mixers and vessels as well as machines for filling liquid and pasty products, **FEIGE FILLING** and **SOMMER** not only deliver complete turnkey solutions, but they also provide round-the-clock service with their after-sales departments. Their own subsidiary companies and highly trained representatives are active worldwide.

Customized engineering along with a cost-effective program of standard components, subassemblies and control systems make **FEIGE FILLING** and **SOMMER** highly attractive partners for customers in the chemicals, pharmaceuticals, petrochemicals, building materials, paint, lacquer, food processing, packaging, and logistics industries. Our customers are supported via our German headquarters in Bad Oldesloe and Düsseldorf, and by our associated companies in France, Brazil, USA, Spain, Poland, China, India and Singapore, as well as our worldwide representatives.



Raw material level

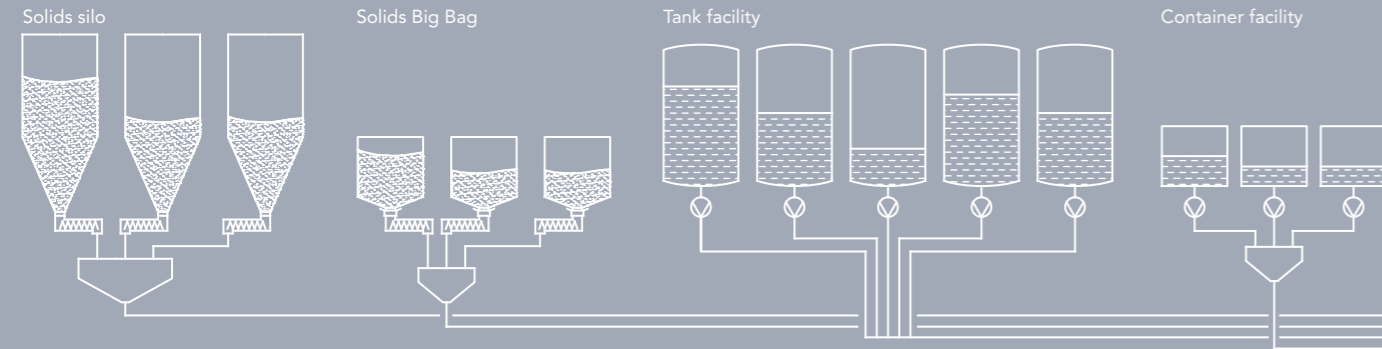

Mixing level

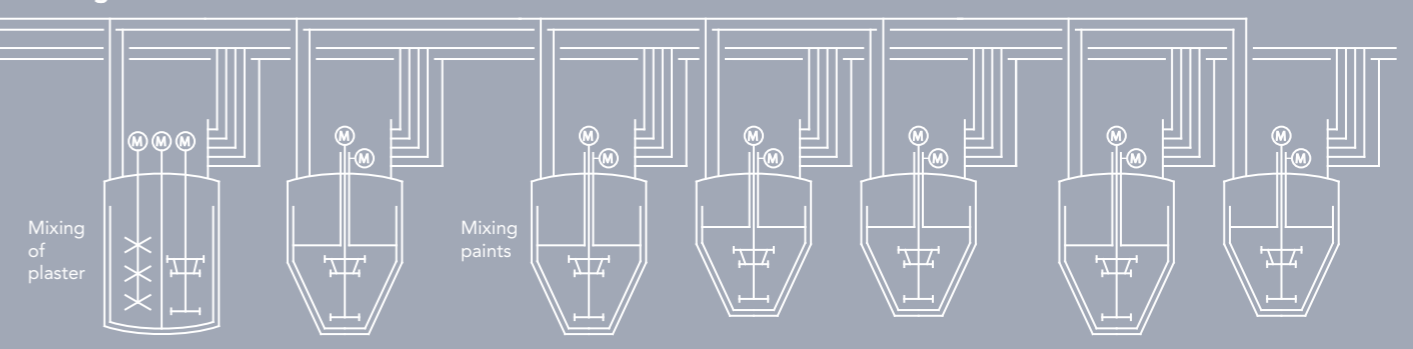

COAXIAL MIXERS

for the intensive mixing and dispersion of low- to high-viscosity products.

Available either with liftable and lowerable dissolver shaft or with fixed dissolver drive. The conical vessel ensures that even extremely small feed batches are dispersed intensively. Operation with minimum liquid requirement also possible.

TRIPLE-SHAFT MIXERS

for short mixing times – also suitable for the mixing and dispersion of large volumes of low- to high-viscosity products, e.g. pastes and thixotropic products.

Utilizes disk helixes for gentle mixing. Right-hand rotation for drawing down solid materials and left-hand rotation for pulling up the mixture in order to aid the dispersion process and remove gas during vacuum mixing.

CIRCULATION DISSOLVERS

for low energy consumption when dispersing low- to medium-viscosity products.

As a result of the vessel shape and the arrangement of the mixer tools, a highly intensive dispersion with fine particle sizes is achieved.

Other advantages:

- minimal liquid requirement
- relatively small batches possible

FREE-STANDING DISSOLVERS

for medium- to high-viscosity media

With a drive power of 22 to 220 kW and stepless rotational speed adjustment, plus hydraulic lifting and lowering. Can be equipped with every conventional mixing tool – especially double-suction dissolvers and double-suction turbines. These mixing tools have proven themselves over the years and ensure exceptionally low-dust, time- and energy-saving processing of powder-type fillers.

LIFTABLE AND LOWERABLE WALL-MOUNTED MIXERS AND DISSOLVERS

for batch sizes between 50 and 2000 liters

With a drive power of 1 to 37 kW, fixed or steplessly adjustable rotational speed – optionally by means of hand wheel regulation or frequency control. Height adjustment can be performed manually or with an electric spindle drive. Can be equipped with every conventional mixing tool – with rapid-exchange device. Optionally with various clamping units for mobile containers.

STEPLESSLY ADJUSTABLE, LIFTABLE AND LOWERABLE LAB AND PILOT PLANT MIXERS

for mixing and dispersing smaller batches

With rapid-exchange device for the mixing tools. Optionally with various clamping units for mobile containers.



Coaxial mixer

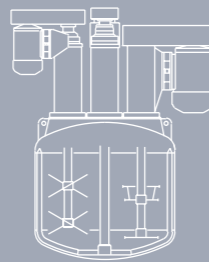

Triple-shaft mixer

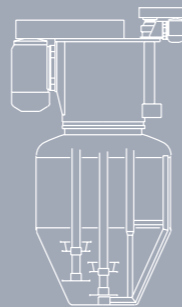

Planetary dissolver

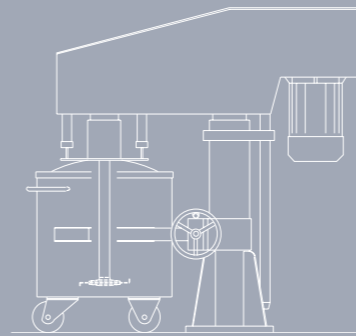

Standing dissolver

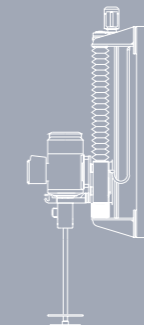

Liftable and lowerable wall-mounted mixer

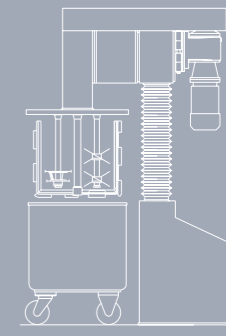

Steplessly adjustable, liftable and lowerable research laboratory mixer

Main application areas:

- Paint and coatings industry
- Chemicals and pharmaceuticals industries
- Paper industry
- Water and sewage treatment sector
- Refineries and the petrochemicals industry
- Power stations and flue gas desulfurization plants
- Textile industry
- Food and beverage industry
- Engineering offices

Product range:

- Mixing, storage and transport vessels
- Pressure and vacuum vessels
- Boiling and melting vessels
- Silo and tank facilities
- Plant engineering
- Heat exchangers, separators
- Pipework
- Steel and special structures
- Agitators and mixers for homogenization, suspension, dispersion, gassing, heat exchange
- Process automation, recipe control, load cell and dosing systems

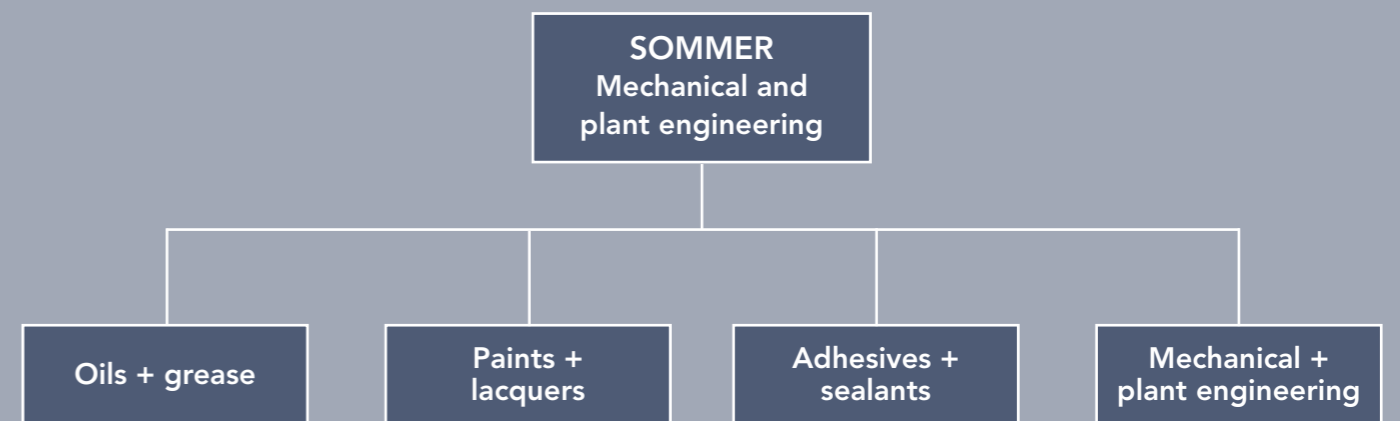

SOMMER GmbH & Co. KG Maschinen- und Anlagenbau

Burgunderstr. 35 · 40549 DÜSSELDORF · Germany

Tel.: +49-211 23082-32 · Fax: +49-211 23082-36

E-Mail: info@sommer-anlagenbau.com

Internet: www.sommer-anlagenbau.com